

Part number:

076-10919a

HYDROMA

HYDRAULICKÉ SYSTÉMY

**HIDROMA
SYSTEMS**

UKŁADY HYDRAULICZNE

HYDROMA

ГИДРАВЛИЧЕСКИЕ СИСТЕМЫ

KF1PG



Porte standard: filetti M6 profondità utile 12 mm.
Fissaggio pompa: n. 2 viti M8, coppia di serraggio $23 \pm 2,4$ Nm.

OPZIONI

"GAS": filetti G3/8 (presenti su entrambi i lati del corpo) profondità utile 12 mm.
A richiesta il modello KF1P è disponibile anche in versione "KA" (porte di aspirazione G3/8 e di mandata G1/4 sul coperchio).

Standard ports: M6 thread depth 12 mm.
To mount the pump: n. 2 M8 screws, with a torque wrench setting fixed at 23 ± 2.4 Nm.

OPTIONS

"GAS": G3/8 thread depth 12 mm. Threads are machined on both body sides.
Upon request, KF1P model is also available in "KA" version (G3/8 as inlet port and G1/4 as outlet port in the cover).

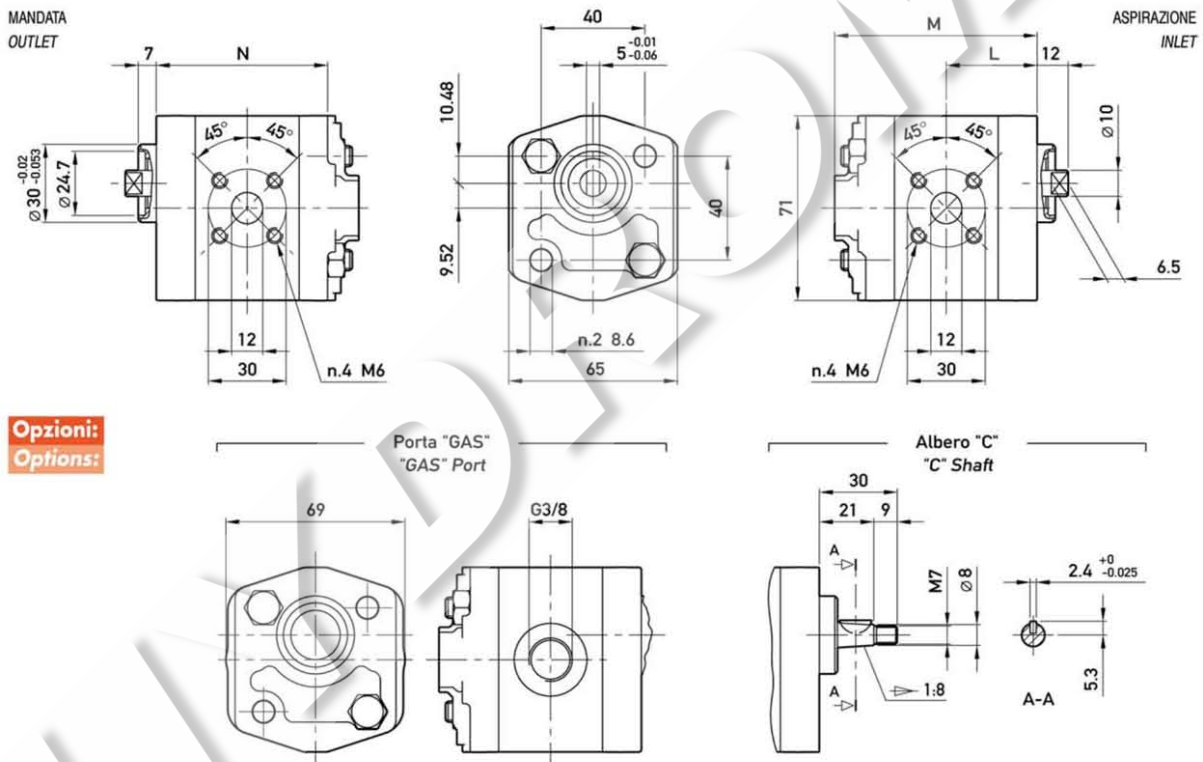

TIPO TYPE	CILINDRATA DISPLACEMENT	PORTATA a 1500 giri/min FLOW at 1500 rev/min	PRESSIONI MASSIME MAX PRESSURE			VELOCITÀ MASSIMA MAX SPEED	DIMENSIONI DIMENSIONS		
			P ₁	P ₂	P ₃		L	M	N
	cm ³ /giro (cm ³ /rev)	litri/min (litres/min)	bar	bar	bar	giri/min (rpm)	mm	mm	mm
KF1P D 1,6 G	1,1	1,6	230	250	270	6000	33	74	62
KF1P D 2 G	1,3	2,0	230	250	270	6000	33,5	75	63
KF1P D 2,5 G	1,6	2,4	230	250	270	6000	34	76	64
KF1P D 3,3 G	2,1	3,2	230	250	270	6000	35	78	66
KF1P D 4,2 G	2,7	4,0	230	250	270	6000	36	80	68
KF1P D 5 G	3,2	4,8	210	230	250	5000	37	82	70
KF1P D 5,8 G	3,7	5,6	210	230	250	4500	38	84	72
KF1P D 6,7 G	4,2	6,4	210	230	250	4000	39	86	74
KF1P D 7,5 G	4,8	7,2	190	210	230	3500	40	88	76
KF1P D 9,2 G	5,8	8,7	190	210	230	3000	42	92	80
KF1P D 11,5 G	8,0	11,9	160	180	200	2100	46	100	88

Part number:

076-10919b

HYDROMA

HYDRAULICKÉ SYSTÉMY

**HIDROMA
SYSTEMS**

UKŁADY HYDRAULICZNE

HYDROMA

ГИДРАВЛИЧЕСКИЕ СИСТЕМЫ

