

Part number:

**HYDROMA**

HYDRAULICKÉ SYSTÉMY

**HIDROMA  
SISTEMS**

UKŁADY HYDRAULICZNE

**HYDROMA**

ГИДРАВЛИЧЕСКИЕ СИСТЕМЫ

VALVOLA DI MESSA A SCARICO CON  
VALVOLA DI MASSIMA PRESSIONE

**VMS-VS-12**

DENOMINAZIONE VALVOLA  
VALVE DENOMINATION

**07010217000000A**

CODICE D'ORDINAZIONE  
ORDERING CODE

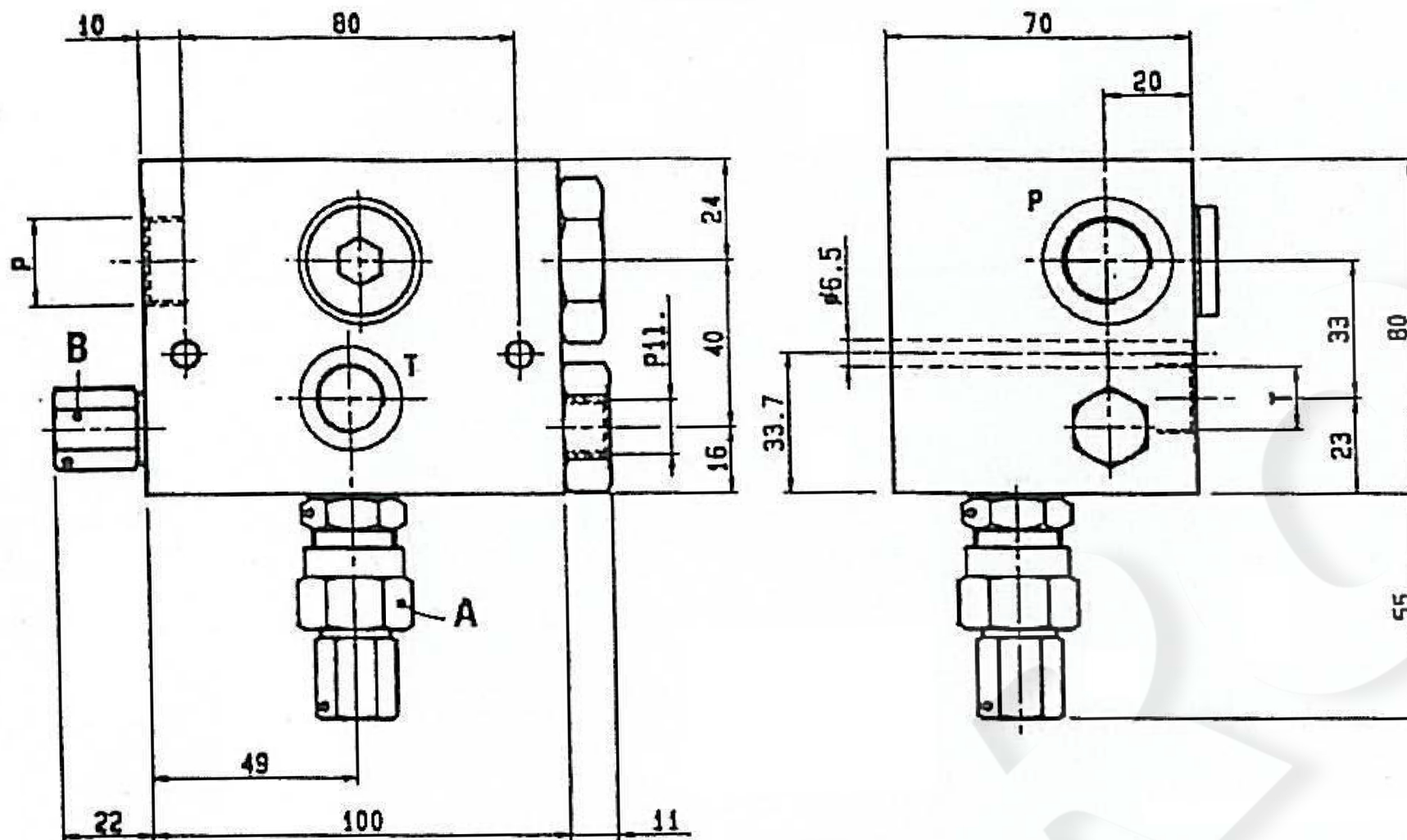

Con fori per piombatura a filo  
With holes for wire-locking

Pressione di lavoro  
max 350 bar

Max working pressure  
350 bar

Portata max della valvola B  
30 l/min

Flow max of valve B  
30 l/min

Peso Kg 1,9

Weight Kg 1,9

REGOLAZIONI  
ADJUSTMENTS

vite interna  
esagono incassato  
leakproof inner hex.  
socket screw

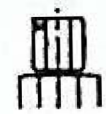

VALVOLA VALVE	MOLLE - SPRINGS				
	Campo taratura min-max bar Adj.press. range bar	Incremento pressione bar/giro vite Pressure increase bar/turn	Taratura standard bar (0-5 1/1') Std.setting bar (made at 5 1/1')	Codice ordinazione Ordering code	Colore Colour
A	10-50	12	40	03.51.01.077	nero black
B	50-210	47	180	03.51.01.075	verde green

	ATTACCHI / PORT SIZE		
	P	T	P11
	1/2" BSPP	3/8" BSPP	1/4" BSPP