

Part number:

HYDROMA

HYDRAULICKÉ SYSTÉMY

**HIDROMA
SYSTEMS**

UKŁADY HYDRAULICZNE

HYDROMA

ГИДРАВЛИЧЕСКИЕ СИСТЕМЫ

**SOLENOID OPERATED VALVES
POPPET 2-WAY NORMALLY OPEN
COMMON CAVITY**

VEI-8I-2A-06-NA-S1-NSS

SIZE 08

OD.15.02.18 - Y - S0

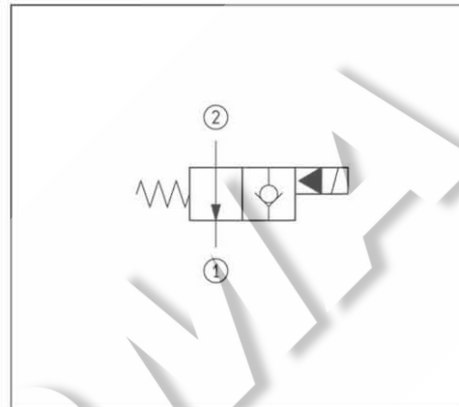
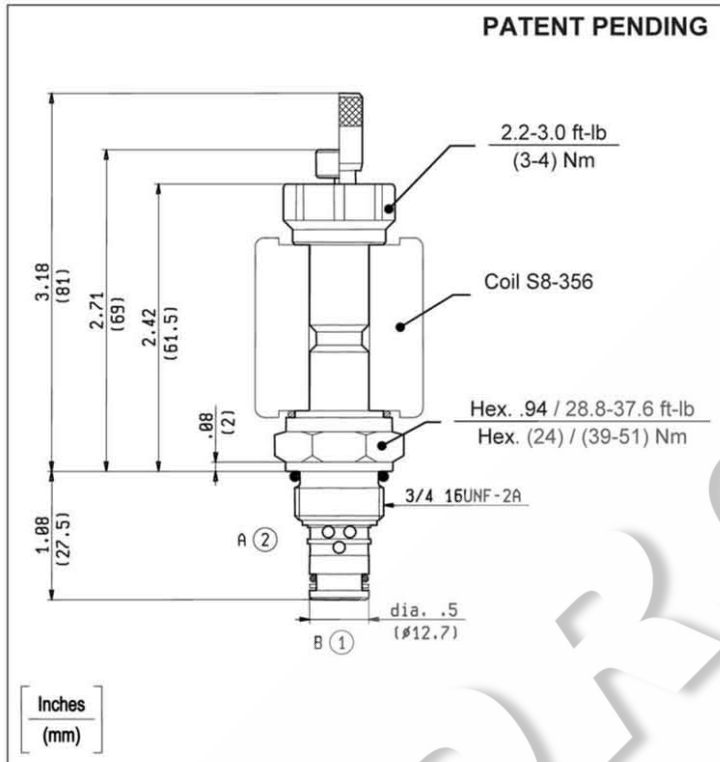

TECHNICAL DATA

Maximum Operating Pressure	5000 psi (350 bar)
Fatigue Cycle Life at 5000 psi (350 bar) and 0.5 Hz (1 s ON - 1 s OFF)	10 million cycles
Rated Flow	8 gpm (30 l/min)
Cavity - Tooling (CA-08A-2N)	page CT.A.001.U
Line bodies	page MN2.A...
Weight	0.286 lbs (0.130 kg)
Fluids - Temperatures	page 7.01.040
Testing Conditions - Seals	page 7.01.040
Internal Leakage	page 7.01.040
Filtration : 25 µm nominal or better	page 7.01.050
Minimum Voltage Required	90% of nominal
Coils must be ordered separately	page 1.71.042
Mounting Position	unrestricted

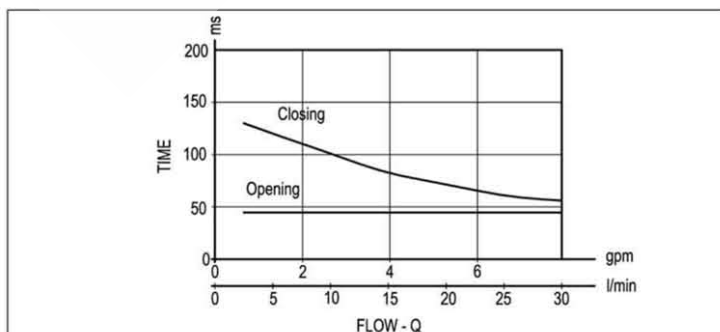
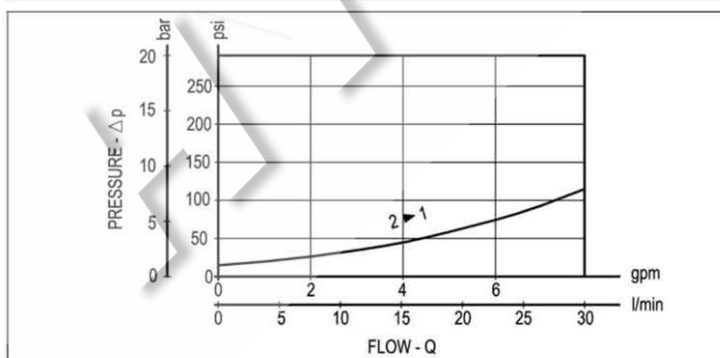

Y	ORDERING OPTIONS	
1I	Standard	
1L	Push Style Manual Override	
1M	Push and Twist Style Manual Override	